



**JOURNAL OF MEDICAL
SIGNALS & SENSORS**

A Quarterly Publication of Interdisciplinary Research

JMSS



 Springer

Editorial Board

CHAIRMAN

Dr Alireza Mehri Dehnavi, PhD, Professor, Department of Biomedical Engineering, Isfahan University of Medical Sciences, Isfahan, Iran.

EDITOR-IN-CHIEF

Dr Hossein Rabbani, PhD, Professor, Department of Biomedical Engineering, Isfahan University of Medical Sciences, Isfahan, Iran.

ASSOCIATE EDITOR

Dr Nasim Dadashi Serej, PhD, Assistant Professor, Medical Image and Signal Processing Research Center, School of Advanced Technologies in Medicine, Isfahan University of Medical Sciences, Isfahan, Iran.

EDITORIAL BOARD

Dr Alireza Mehri Dehnavi, PhD, Professor, Department of Biomedical Engineering, Isfahan University of Medical Sciences, Isfahan, Iran.

Dr Leyuan Fang, PhD, Professor, College of Electrical and Information Engineering, Hunan University, China.

Dr Keyvan Jabbari, PhD, Assistant Professor, Department of Medical Physics, Isfahan University of Medical Sciences, Isfahan, Iran.

Dr Brian J. Lithgow, PhD, Associate Professor, Senior Research Fellow, Alfred Psychiatry Research Centre; Leader, Diagnostic and Neurosignal Processing Research Group Monash University, Victoria, Australia.

Dr Ali Moeeny, MD PhD, Laboratory of Sensorimotor Research, National Eye Institute, National Institutes of Health, USA.

Dr Majid Mohammad-Beigi, PhD, Department of Bioinformatics, Isfahan University, Isfahan, Iran.

Dr Mojgan Mokhtari, MD, Professor, Department of Pathology, Isfahan University of Medical Sciences, Isfahan, Iran.

Dr Mohammad-Hassan Moradi, PhD, Professor, Department of Biomedical Engineering, Amirkabir University of Technology, Tehran, Iran.

Dr Zahra Moussavi, PhD, Professor, Department of Electrical & Computer Engineering, University of Manitoba, Canada.

Dr Reza Nezafat, PhD, Professor, Division of Cardiovascular Medicine, Department of Medicine, Harvard Medical School, Boston, MA, United States.

Dr Saeed Sadri, PhD, Professor, Department of Electrical and Computer Engineering, Isfahan University of Technology, Isfahan, Iran.

Dr Hossein Saeedi, PhD, Professor, Department of Electrical and Computer Engineering, Isfahan University of Technology, Isfahan, Iran.

Dr Mahmoud Saghaei, MD, Professor, Department of Anesthesia, Isfahan University of Medical Sciences, Isfahan, Iran.

Dr Hamidreza Saligheh-Rad, PhD, Associate Professor, Department of Medical Physics and Biomedical Engineering, Tehran University of Medical Sciences, Tehran, Iran.

Dr Vincent Vigneron, PhD, Associate Professor, Department of Computer Engineering, Evry University, Evry, France.

SECTION EDITORS

Dr Mahdad Esmaeili, PhD, Assistant Professor, School of Advanced Medical Sciences, Tabriz University of Medical Sciences, Tabriz, Iran.

Dr Saeed Karbasi, PhD, Professor, Department of Biomaterials and Tissue Engineering, Isfahan University of Medical Sciences, Isfahan, Iran.

Dr Maryam Atarod, PhD, Assistant professor, School of Allied Medical Sciences, Shahrekord University of Medical Sciences, Chaharmahal and Bakhtiari, Iran.

Dr Raheleh Kafieh, PhD, Assistant Professor, Department of Biomedical Engineering, Isfahan University of Medical Sciences, Isfahan, Iran.

Dr Hamid Reza Marateb, PhD, Associate Professor, Biomedical Engineering Department, University of Isfahan, Isfahan, Iran.

Dr Alireza Mehri Dehnavi, PhD, Professor, Department of Biomedical Engineering, Isfahan University of Medical Sciences, Isfahan, Iran.

Dr Mahmoud Saghaei, MD, Professor, Department of Anesthesia, Isfahan University of Medical Sciences, Isfahan, Iran.

Dr Mohammadreza Sehhati, PhD, Assistant Professor, Department of Biomedical Engineering, Isfahan University of Medical Sciences, Isfahan, Iran.

EXECUTIVE MANAGER

Ms. Saba Ajami, M.Sc., Medical Image and Signal Processing Research Center, Isfahan University of Medical Sciences, Isfahan, Iran.

Design and Development Armband Vital Sign Monitor for Health-Care Monitoring

Abstract

Background: One of the vital organs that require regular check is heart. The representation of heart health can be identified through electrocardiogram (ECG) signals, blood pressure (BP), heart rate, and oxygen saturation (SpO₂). Monitoring the heart condition needs to be regularly done to prevent heart attack that can occur suddenly and very quickly particularly for someone who has had a heart attack before. Nevertheless, it raises the problem of cost, time efficient, and flexibility. It takes a high cost and much time to perform this examination. A vital signal monitoring device is needed with low cost, wearable, accurate, and simple in use. **Methods:** This research designs and develops a device and application for monitoring human vital signals including ECG, SpO₂, BP, and heart rate. A multi-sensor system with a control unit was applied to the device which was then called the Armband Vital Sign Monitor. This device can be used to measure vital parameters simultaneously using multiplexing techniques programmed in the microcontroller. Armband vital sign monitor is also equipped with Bluetooth module as a communication media for further data processing and display. **Results:** Armband vital sign monitor produces >99% accuracy in body temperature measurements, ± 2 deviation values in SpO₂ measurements, and systolic and diastolic deviations at $\pm 3-8$ mmHg. For ECG signals, tests are performed by comparing signals visually in graphical form, and ECG can be obtained properly as shown by the graph. **Conclusion:** In this study, an Armband vital sign device has been developed that can measure the body's vital parameters. The parameters which were measured included temperature, heart rate, BP, SpO₂, and ECG. This device has small dimensions and can be put on the wrist. The device is also equipped with Bluetooth so monitoring can be conducted wirelessly.

Keywords: Armband vital sign, blood pressure, electrocardiogram, heart, oxygen saturation

Submitted: 09-May-2020

Revised: 20-May-2020

Accepted: 19-Jul-2020

Published: 21-Jul-2021

Introduction

Wearable medical device that support high mobility have been widely developed recently. This issue has been described by Sundaravadivel^[1] called smart health care as an internet of things application. This medical device is commonly used for continuous monitoring of human vital sign conditions through noninvasive measures.^[2] One important parameter of a person's physical condition that must be periodically examined is the heart to prevent heart attacks that can occur suddenly.^[3] The physiological signals that describe the condition of heart health can be identified through electrocardiogram (ECG) examination, heart rate, blood pressure (BP), and oxygen

saturation (SpO₂). The observation of these parameters for those with a history of heart disease should be done continuously not limited to the place and time meaning that people not only should do the medical check-up in health-care center but also can observe the physical condition by themselves. In developing countries with large areas and populations with minimum health facilities, it highly needs medical device that is wearable, reliable, highly mobile, highly accurate but low in price, especially for heart health examination. Through this device, people are able to perform an early check of their heart health condition and when abnormalities are detected, an immediate prevention and further examination may be taken in the hospital.

Some researchers have made a device and system application of vital sign monitor but

This is an open access journal, and articles are distributed under the terms of the Creative Commons Attribution-NonCommercial-ShareAlike 4.0 License, which allows others to remix, tweak, and build upon the work non-commercially, as long as appropriate credit is given and the new creations are licensed under the identical terms.

For reprints contact: WKHLRPMedknow_reprints@wolterskluwer.com

How to cite this article: Hadiyoso S, Tulloh R, Rohmah YS, Alfaruq A. Design and development armband vital sign monitor for health-care monitoring. *J Med Sign Sens* 2021;11:208-16.

**Sugondo Hadiyoso,
Rohmat Tulloh,
Yuyun Siti Rohmah,
Akhmad Alfaruq**

*Diploma of Telecommunication
Technology, School of Applied
Science, Telkom University,
Bandung, Indonesia*

Address for correspondence:
Sugondo Hadiyoso,
School of Applied Science,
Telkom University,
Bandung 40257, Indonesia.
E-mail: sugondo@
telkomuniversity.ac.id

Access this article online

Website: www.jmssjournal.net

DOI: 10.4103/jmss.JMSS_29_20

Quick Response Code:



some only have been focused on ECG signal.^[4-8] In certain conditions, to do a diagnosis on health of hearth, it also requires the examination of other parameters. Another study on the realization of vital sign for the hearth examination with more than one parameter was conducted.^[9] In that study, a modular vital sign monitoring was realized for the examination of ECG, SpO2, and body temperature but hardware was not placed in one board; as a consequence, it became less flexible if used for the examination at the same time. In a study,^[10] a Wearable Vital Signs Monitor was made and installed on ears to monitor the heart rate continually through the signal of ECG and photoplethysmography (PPG) but it did not discuss about the measurement of SpO2. A study by Shivakumar and Sasikala^[11] was to design a mini patient monitoring system to measure the vital parameters such as ECG, Heart Rate, and Respiration Rate without any BP meter and SpO2.

In developing countries with the large population rate where the health facilities have not been entirely fulfilled for each area, a device for the examination of the body vital condition that can be used individually is deemed important. In this paper, an embedded, wearable, and mobile armband vital sign monitor that can be used for measuring of ECG, BP, SpO2, heart rate, and body temperature is designed and demonstrated. This device consists of a sensor and a module integrated on one circuit board with a microcontroller as its main unit. This vital sign monitor was then packaged in a casing that is wearable on wrist making it simple to be used. Sensor and transducer can be installed modularly in accordance to the needs of examination. The device uses an interface Bluetooth as a communication media with personal computer (PC). Through the application program, the signal data can be represented through the graphic and number enabling a further analysis to be done. For a further development in future, this system can be a prototype or model that can be applied in the health-care center or by individual.

Methods

Vital sign monitor

In general, vital sign monitor can be defined as a medical device that is able to acquire a number of important health parameters and then it is displayed in the graphic and numerical form. Such medical device is also known as multiparameter patient monitor. The signals displayed on the multiparameter patient monitor include ECG signal, respiratory, noninvasive BP, SpO2, pulse rate, and temperature as shown in Figure 1 is an example of a vital sign monitor application.^[12] In this device, all signals have been displayed simultaneously either in the graphic or in numerical forms for the further analysis by the medical experts. In this research, the health parameters measured included ECG, BP, SpO2, heart rate, and body temperature. Taking this vital signal was done simultaneously or by selecting certain parameters in accordance with the needs of observation.



Figure 1: The example of vital sign monitor application

Electrocardiogram

ECG is a description of the electrical potential generated by the electrical activities of hearth muscles. To take the ECG signal can be done by installing the electrodes on certain spots of body as a media of electrical conductor for the further process. The important information about the functional aspects of the heart and cardiovascular system can be obtained through the ECG signal.^[13] The form of normal ECG signal is shown in Figure 2.

ECG measurement could be done through two modes: diagnosing mode and monitoring mode. Diagnosing mode saw the ECG signal in the wide frequency range (0.05–100) Hz to see the valuable information from the signal. This mode commonly is used to diagnose any hearth disorder.^[14] In monitoring mode, it is commonly to only see the rhythm of hearth. This mode has a narrower frequency of ribbon in the range of 0.05–40 Hz.^[14] The advantage of this mode is that a large amount of high frequency noise can be removed and the effects of body movements can be reduced.^[14] In this study, the ECG device was designed with the monitoring mode in the lead I configuration. The spot of the electrode installation on the body of the chest is shown in Figure 3 based on the Einthoven's triangle.

Oxygen saturation

SpO2 refers to one of the important physiological parameters showing the level or content of oxygen in blood. This measurement is commonly called as SpO2 using a set of oximeter pulse. In a normal condition, the value of the oxygen level is in the range of 95%–100%. If the oxygen level is less than the referred value, it indicates that the blood contains the very low level of oxygen. If the oxygen drops into a normal level ($\leq 92\%$), there is a possibility that the body suffers from the hypoxemia disease. The patient of hypoxemia usually suffers from coughing, accelerated heart rate, delirious state of mind, or sweating.^[15] The design of the hardware of pulse oximeter is shown in Figure 4. The principle of its work is by

emitting the light from one side of finger to the detector on the other side through the tissue, venous blood, and arterial blood. The light absorption on the detector is varied based on the blood volume and the wavelength of light source.

The SpO₂ measurement is compared to the light absorption in the photodetector of the two different wavelengths of

Infra-Red (940 nm) and Red Led (660 nm) as written in the equation below:^[16]

$$R = (AC_{RED}/DC_{RED})/(AC_{IR}/DC_{IR}) \tag{1}$$

The value of SpO₂ can be calculated by inserting the R value on the linear equation 2.^[17]

$$SpO_2 = 110 - 25 \times R \tag{2}$$

Blood pressure

Vital signal refers to the mechanical signal of hearth called as the BP. BP is generated by blood pumping activity by the heart.^[18] BP is the measure to what extent the strength of the pressure which is generated by the heart when the blood is pumped in the blood vessel.^[19] The pressure can be measured in the ventricle, aorta, arterial blood vessel, or venal BP. However, in the BP measurement clinically, the one commonly measured is the BP in the arterial blood vessel.

BP contains the important information stating the level of the hearth health and the blood vessel of an individual. The values in the BP in addition to the systolic pressure or diastolic pressure can be formulated as follows.^[20]

$$\text{Average} = 0,5 \times (\text{Sys} + \text{Dias}) \tag{3}$$

$$\text{Mean arterial pressure} = 1/3 \times (\text{Sys} - \text{Dias}) + \text{Dias} \tag{4}$$

The technique used in the measurement of BP in this research was oscillometry. Oscillometry uses the pressure sensor to detect the pressure generated by cuff, translated by microprocessor, and then displayed in the numeric form of systolic and diastolic pressure.

Implementation

The design of vital sign monitor hardware is based on the functionality, excellence, mobility, and certainly able to be wore on the wrist. The function that must be run by

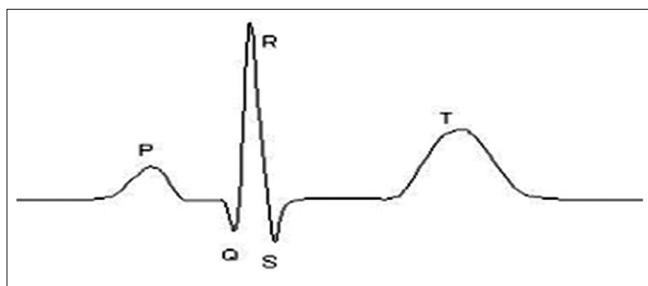

Figure 2: Normal electrocardiogram signal

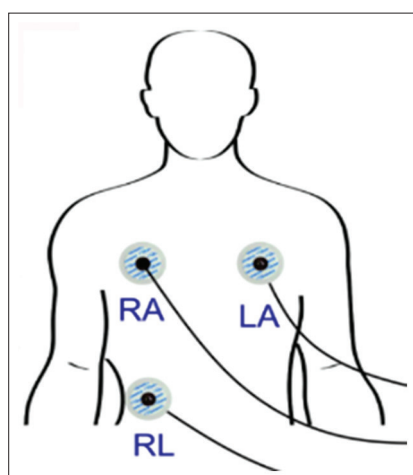

Figure 3: Electrode placement

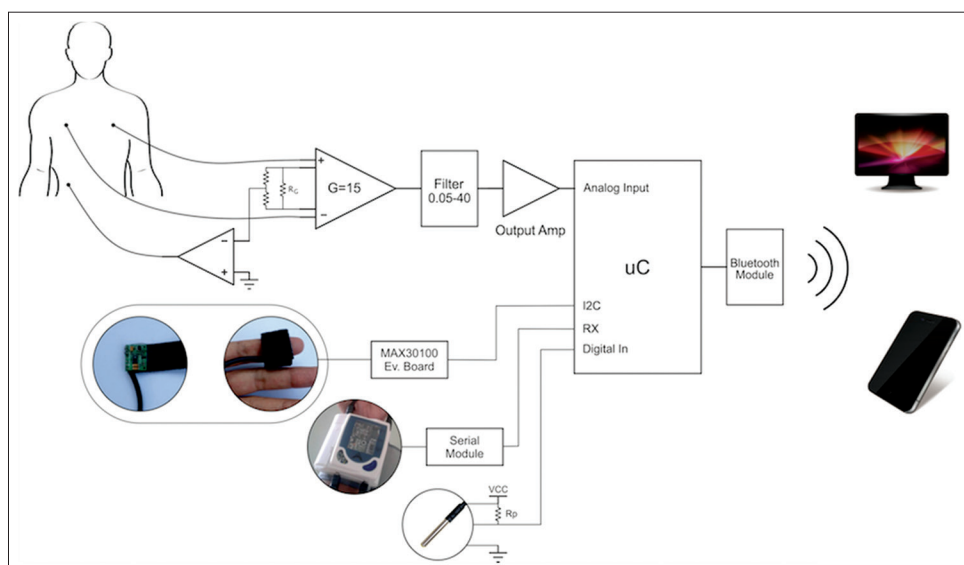

Figure 4: Design of hardware

the device is that it can take the ECG signal, SpO2, BP, and body temperature. The main power source is the low capacity battery DC 3.7 Volt to ascertain the safety in case there would be any errors in circuit. The design of the device also considers the size to make it able to be used on the wrist and to have high mobility. The design of the hardware of armband vital sign monitor in this research is shown in Figures 4 and 5.

Electrocardiogram design

Taking the signal of ECG was through the electrode installed on the chest forming the configuration of Einthoven's triangle. With the installation of the electrode on the chest, it is expected that the signal of ECG obtained can have little noise as it is close to the signal source that is hearth. The instrument of ECG consists of the instrumental supports, filter of LPF and HPF, operational supports, and a circuit of signal shifter. Based on the recommendation of Anaesthesia UK,^[14] on monitoring mode, the cutoff of low frequency is 0.05 Hz and the high one is 40 Hz. In this research design, it was implemented with 0.05 Hz for a high-pass filter and 40 Hz for a low-pass filter.

The circuit of the instrumental supports was used to strengthen the signal from two spots of electrode sources. With the instrumental support, the signal of information would be strengthened maximally and the noise can be minimized using the support with the large common-mode rejection ratio. The additional electrodes as the driven right leg (DRL) installed on the lower right chest was used as the additional reference to minimize the noise. The circuit of the instrumental supports and DRL is described as follows.

The ECG signal was amplified by 15 times by adjusting the values of RG in line with the following equation.

$$G = 1 + \frac{50K}{RG} \tag{5}$$

From the equation above, it could be obtained the value of RG by 3, 8 KΩ.

The circuit of high pass filter [Figure 6] on the system proposed is the filter of passive order 1 (equation 6) consisting of the capacitor and resistor.

$$f_c = \frac{1}{2\pi RC} \tag{6}$$

The proposed system used ADC in the range of 0–5 Volt, and to ensure that the signal has had the voltage at the positive level; it then required the level shifter as shown in Figure 7.

Oxygen saturation module

The measurement of SpO2 is performed using the SpO2 module. It is designed using IC max30100 which can

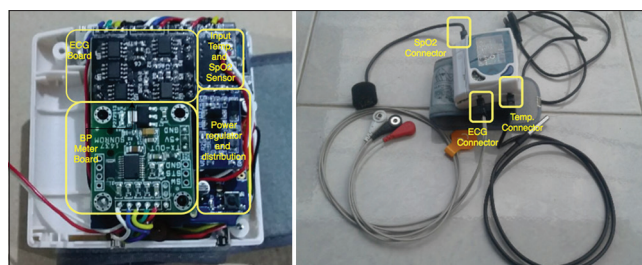

Figure 5: Hardware implementation

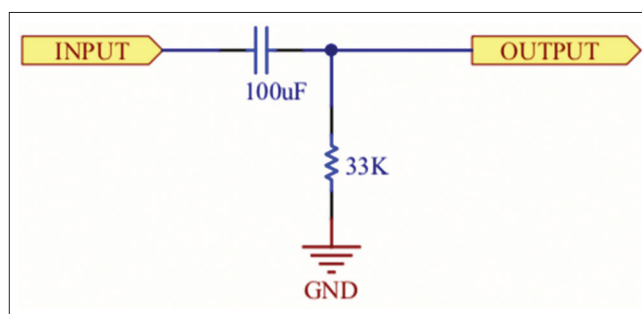

Figure 6: High-pass filter 0.05 Hz circuit

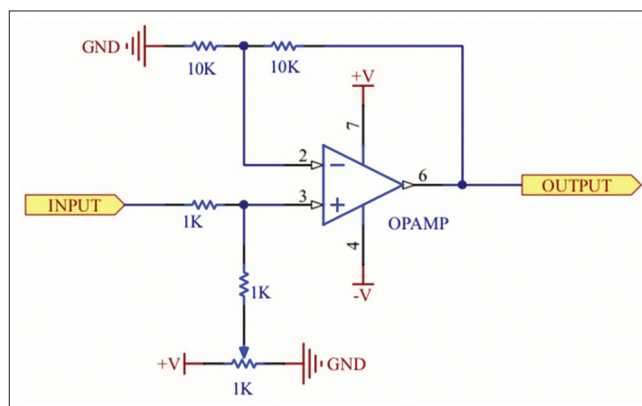

Figure 7: Level shifter circuit

measure the pulse rate and SpO2. However, in this study, it only used to measure the SpO2. IC max30100 was built in LED and IR as the light source and detector to make the circuit design simpler. Max30100 still needed the system of minimum supporting components on a board to enable it working well. It also requires the pull-up resistor and capacitor in the data communication pin and power in accordance with the requirement on the datasheet. SpO2 data have a digital format output which can access using the standard of I2C communication. Serial Data (SDA) and Serial Clock (SCL) pin were connected directly to the microcontroller pin to control the clock and data transmitting. SpO2's Hardware setup and the typical of the circuit of max30100 are shown in Figures 8 and 9 as follows:

Algorithm for reading data of max30100:

Include library:

1. Arduino.h //Use Arduino library for compiler

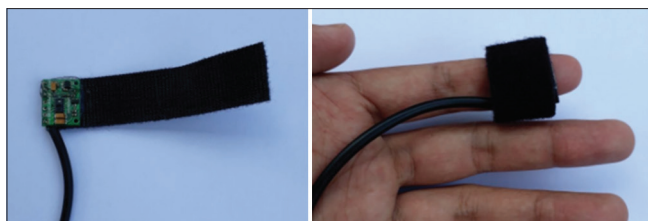

Figure 8: Oxygen saturation's hardware setup

2. Wire.h //I2C
3. math.h //math.operation
4. max30100.h //hardware description

I/O Setup:

5. Serial comm. Bd 115200
6. I2C (SDA, SCL, pin 27 and 28)

Main process:

7. If pulse detected//check whether the sensor detects the pulses
//read AC, DC signal led and IR
8. Then (read AC component from led and IR)
(read DC component from led and IR)
9. Calculate ratio
$$R = (AC_{led}/DC_{led})/(AC_{IR}/DC_{IR})$$
10. Calculate SpO2 value.
SpO2 value = $R * (110.0 - 25.0)$

Output

11. I2C read address (AF_{IR})//address for read data
12. Wire.write (address)//sends address for request data
13. Serial print data SpO2.

Blood pressure meter

The measurement of BP in this research was conducted using the commercial wrist digital BP meter from Sunrom. This BP meter supported the serial data communication to facilitate the development. An interface with controller was through universal asynchronous receiver transmitter (UART) at the speed rate of 9600 Bps (8 bits data, No parity, and 1 stop bits). The parameters measured included: systolic, diastolic, and pulse in the form of the data of ASCII 15 bytes with the length of each byte at 0–255 in decimal. The typical format data used in this research was:

- Systolic : Bytes (1–3)
- Diastolic : Bytes (6–7)

To easily representing the data and reading the numeric, it then required the conversion from ASCII to the integer using the following equation:

$$\text{Dec} = ((\text{bytes}[1] - '0') \times 100) + (\text{bytes}[2] - '0') \times 10 + (\text{bytes}[3] - '0')$$

Digital temperature sensor

The design of the digital temperature on the armband vital sign monitor was based on the module of DS18B20. Typically, the range of measurement is from -55°C to $+125^{\circ}\text{C}$, and it is very good to be used for measuring the

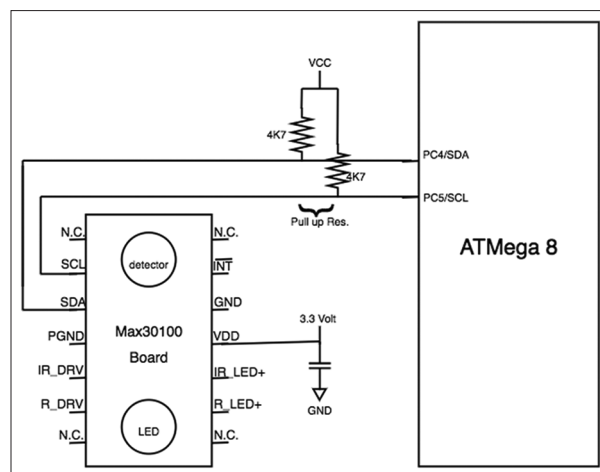

Figure 9: Oxygen saturation sensor schematic

body temperature. The DS18B20 communicates with the controller unit through the interface 1-Wire/1-digital data line. It also requires the pull-up resistor connected between pin power and data purposely to be able to work properly.

Main controller unit

Main controller unit consist of ATMEGA8-16A chip as main component. The main function is to read the data (both of analog and digital) from all devices/modules of signal acquisition that used in this study. Microcontroller also has function to manage the format of data to prevent any errors in representing the data in the application side. In the ATmega-8 chip, an Arduino firmware/bootloader system is planted, so programming and uploading the algorithms can be performed through the Arduino IDE. In reading the data, the controller board has a function as the interface of all sensor modules including ECG through analog to digital conversion line (PC0), SpO2 (Max30100) using I2C lines (SDA and SCL), BP meters using virtual serial (PD2) which is generated using library serial Arduino IDE and temperature sensors using digital interfaces (PD3). Schematic and wiring of the main controller unit including power distribution and I/O is shown in Figure 10. In the data transfer stage through Bluetooth module (HC-06), UART communication standard is used. When sending the data, the microcontroller works like a digital multiplexer. Data or signals that are read are then sent alternately with the following protocol: SpO2 is sent/30 s, temperature is sent/60 s, ECG sampling/10 milli s, and BP according to the button activation on the device.

Results and Discussion

The implementation of hardware for the important body signal acquisition as explained in the chapter above has been conducted. Each module was integrated in a main controller board designed compactly and precisely to make it compatible with the casing of BP meter digital. A battery

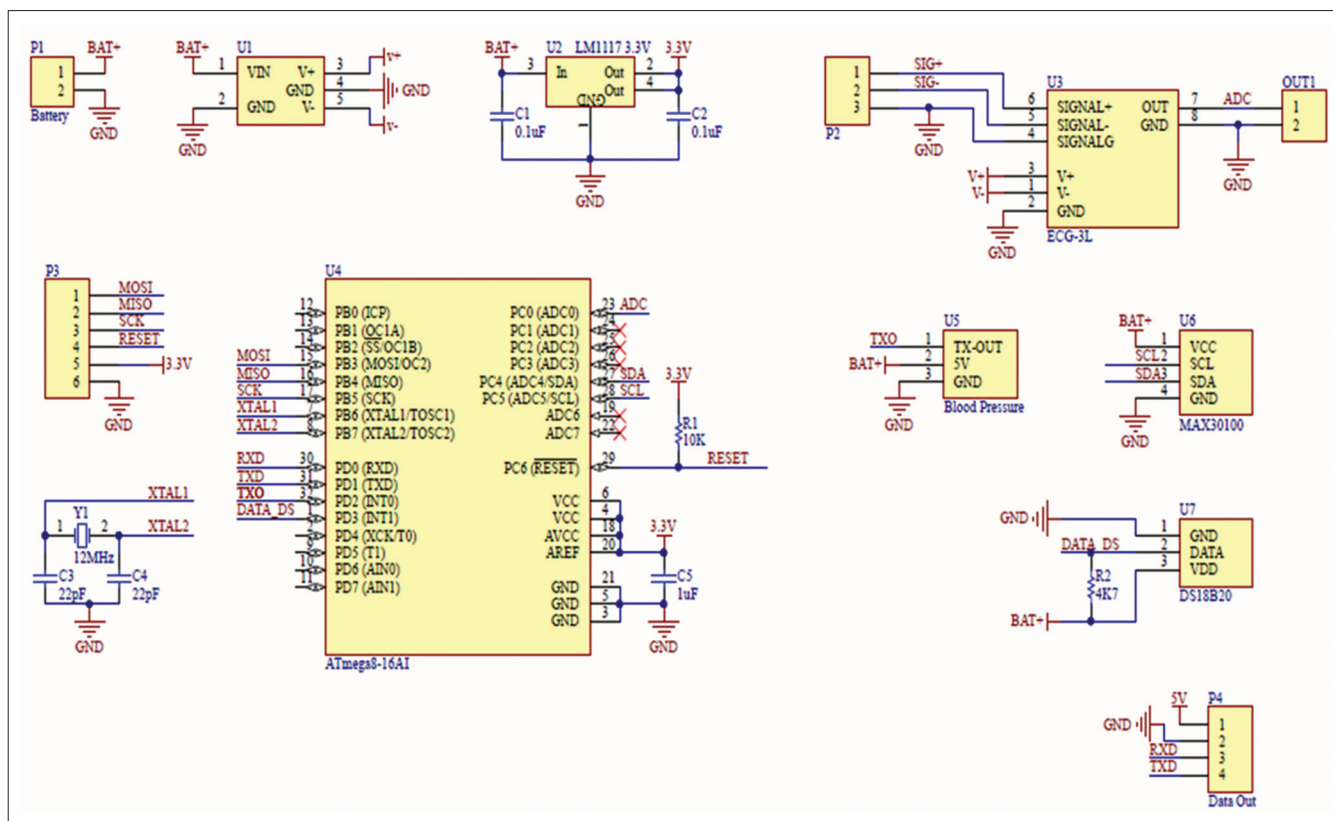

Figure 10: Main controller unit

type 16340; 3.7 Volt; 700 mAh was used as the main power. In its use, this device is installed on wrist as shown in Figure 11.

The testing was conducted to observe the performance of the device by comparing with the standardized device. The result of the comparison was in the form of signal and numerical graphics. The representation of body parameter measured was displayed in the real-time PC application program through the Bluetooth communication.

Initial validation

Data acquisition hardware has been successfully realized and was able to acquire the parameter of body vital referred. For the initial validation, the data of vital body sent by the microcontroller was observed with the aid of serial monitor application. The sample of the result of measurement displayed in the serial monitor is shown in Figure 12.

From the result of the acquisition of vital body as shown in Figure 12 in the integer form, it can be concluded that the device made is able to work well. The device could read the data from the sensor and send the data simultaneously for further processing. Each of data line is the value of measurement parameter separated by semicolon with the order of SpO2, Temp, ECG (label A) and Sys, and Dias (label B). Then, the application



Figure 11: Device installation

would represent the data format in the graphic and numerical form.

Temperature measurement

The steps conducted were by doing the test on accuracy that is by comparing the result of the temperature measurement in which the device made using digital thermometer. The measurement was done by 15 times with the varied temperatures and then the error value was measured in each measurement. The result of the measurement is presented in Table 1 and Figure 13.

From the result of the measurement comparison to the value of temperature, it obtained the error value of ± 0.7 or 0.428%. This error value was relatively small and assumed still to fulfill the standard requirement. Hence, the device can be claimed to be proper for use.

Acquisition of electrocardiogram signal

The test on the ECG signal was conducted visually by comparing the form of signal which is generated by the device and EDAN PC ECG as standardized ECG device. This test was to compare visually the graphic which is generated by the device through the application program. A direct test was done by placing the electrode on the ECG simulator (Fluke PS400). The result of the test is shown in Figure 14.

From Figure 14, the data of ECG signal lead 1 could be displayed well. Those two application programs showed the basic form of ECG signal was similar in which the wave of PQRST could be seen clearly. Thus, the result of the acquisition of ECG signal will be able to be used

as a base for the medical practitioners to determine the health condition of heart.

Accuracy of digital blood pressure meter

The measurement was done by 10 times with different person using BP meter Omron 7120 for comparison with the proposed device. The result of measurement is shown in Table 2. The deviation value in the measurement of systolic and diastolic pressure was $\pm 3-8$ mmHg.

Accuracy of digital oxygen saturation

The steps conducted in the test on the accuracy of SpO2 were by comparing the result of the measurement of the SpO2 by means of a device made with the pulse Oximeter Contec CMS50M. The measurement was done by 10 times and continued by measuring the deviation value in each measurement. The measurement results are presented in Figures 15 and 16 and Table 3. The deviation value obtained was ± 2 in which this value commonly was in the tolerance threshold of the SpO2 device.

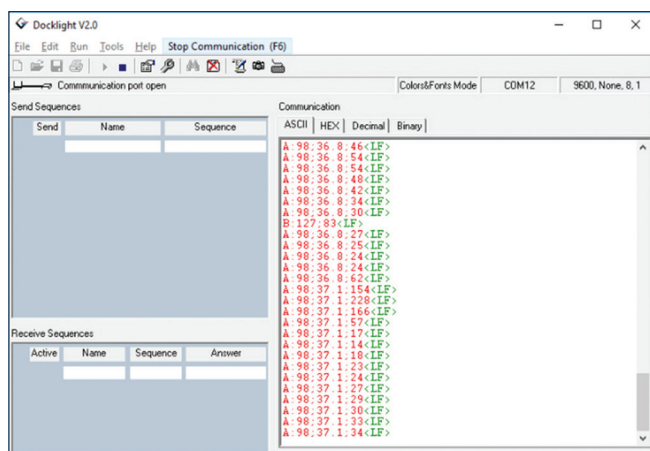

Figure 12: Data samples on a serial monitor

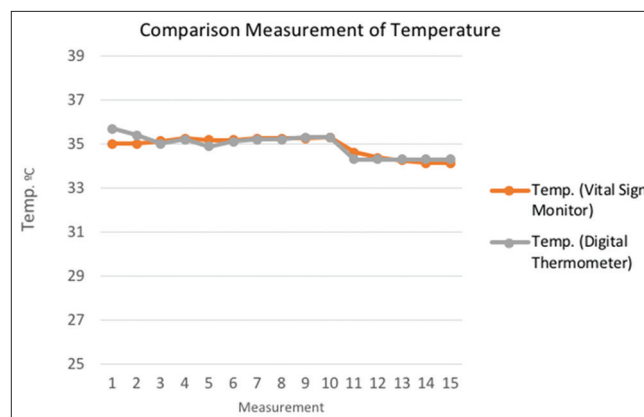

Figure 13: Temperature measurement

Table 1: Results of temperature measurement

Measurement number	Temperature (vital sign monitor) °C	Temperature (digital thermometer) °C	Percentage error
1	35	35,7	1,9
2	35	35,4	1,1
3	35,13	35	0,3
4	35,25	35,2	0,1
5	35,19	34,9	2
6	35,19	35,1	0,2
7	35,25	35,2	0,1
8	35,25	35,2	0,1
9	35,25	35,3	0,1
10	35,31	35,3	0,02
11	34,63	34,3	0,1
12	34,38	34,3	0,2
13	34,25	34,3	0,1
14	34,13	34,3	0,5
15	34,13	34,3	0,5



Figure 14: (a) Electrocardiogram waveform from proposed device (b) electrocardiogram waveform from EDAN electrocardiogram

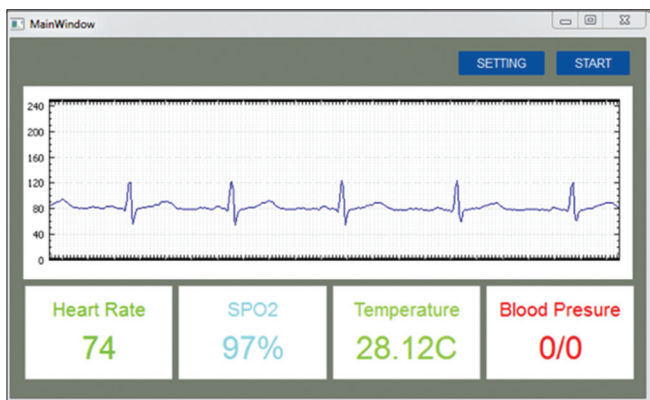

Figure 15: Sample display of oxygen saturation measurement

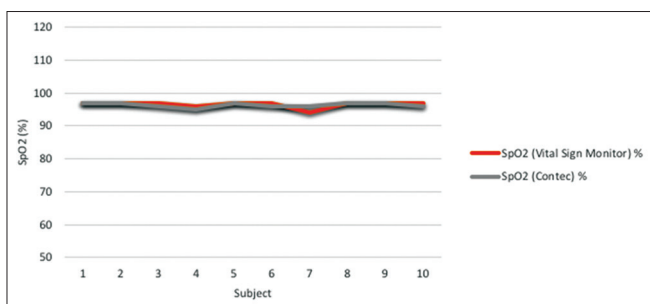

Figure 16: Comparison measurement of oxygen saturation

Testing of communication range

The proposed device uses a Bluetooth HC-06 as serial module for data transmission to a display device. The purpose of this test is to find out the maximum range where the vital sign device can still transmit data to the receiver. The test is conducted under line of sight condition. From the test results shown in Table 4, the maximum range that can be reached is 10 m, if more the connection is become lost so that manual reconnecting is required for the data to be received. This Bluetooth module makes the proposed device can be used easily, with high mobility and flexibility when used for self-monitoring or by clinicians.

Conclusions

This paper presents the implementation of medical device for the acquisition of vital body signal (ECG, SpO2 pulse

Table 2: Blood pressure measurement

Patient	Device		Omron 7120	
	Sys mmHg	Dias mmHg	Sys mmHg	Dias mmHg
1	138	87	130	96
2	143	90	140	100
3	144	90	140	87
4	114	75	117	78
5	99	67	100	70
6	118	85	122	92
7	117	86	120	90
8	125	93	130	96
9	101	67	101	70
10	96	67	99	70

Table 3: Accuracy of digital oxygen saturation

Subject	SpO ₂ (vital sign monitor) (%)	SpO ₂ (contec) (%)	Error
1	97	97	0
2	97	97	0
3	97	96	0
4	96	95	1
5	97	97	0
6	97	96	1
7	94	96	2
8	97	97	0
9	97	97	0
10	97	96	1

SpO₂: Oxygen saturation

Table 4: Bluetooth range performance

Range (m)	Status
1	received
2	received
3	received
4	received
5	received
6	received
7	received
8	received
9	received
10	received
>10	not received

rate, tension meter and body temperature). The device has a compact design on a board that is compatible with the casing of BP meter digital. This device uses a battery as the main power and Bluetooth module as its interface to enable this device able to be used in mobile and installed on the wrist. The body signal can be taken simultaneously or partially in accordance with the needs of medical measurement. From the test result, it obtained the error by 0.428% in the measurement of body temperature, deviation value of ± 2 in the measurement of SpO₂, and deviation in the systolic and diastolic at $\pm 3-8$ mmHg. For ECG signal, the test was conducted by visually comparing the signal

in the graphic form, and ECG could be acquired well as shown by the graph. The future research that be conducted is to design the configuration of the network of internet in the form of gateway, server, client, and its application to be able to support the online real-time application.

Acknowledgment

Authors gratefully acknowledge the support of Ministry of Research and Technology of Higher Education (Kemenristekdikti) of the Republic of Indonesia, through "Penelitian Strategis Nasional Institusi" (Institution National Strategic Research) for financial support. We are also grateful for School of Applied Science, Telkom University, for providing the laboratory and testing tools for the prototype implementation.

Financial support and sponsorship

None.

Conflicts of interest

There are no conflicts of interest.

References

- Sundaravadevel P, Kougianos E, Mohanty SP, Ganapathiraju MK. Everything you wanted to know about smart health care. *IEEE Consum Electron Mag* 2018;7:19-28.
- Lopez G, Sasaki K, Hosaka H, Itao K. Integrating Wearable Sensing and Information Technologies for Human Healthcare Support, in APBME 2003 - IEEE EMBS Asian-Pacific Conference on Biomedical Engineering 2003; 2003. p. 94-5.
- World Health Organization. *Avoiding Heart Attacks and Strokes Don't be a Victim Protect Yourself*, Booklet, Geneva: World Health Organization; 2005.
- Gia TN, Thanigaivelan NK, Rahmani AM, Westerlund T, Liljeberg P, Tenhunen H. Customizing 6LoWPAN networks towards Internet-of-Things based ubiquitous healthcare systems, in NORCHIP 2014 - 32nd NORCHIP Conference: The Nordic Microelectronics Event; 2014. p. 1-6.
- Preejith SP, Dhinesh R, Joseph J, Sivaprakasam M. Wearable ECG platform for continuous cardiac monitoring. *Conf Proc IEEE Eng Med Biol Soc* 2016;2016:623-6.
- Liu SH, Cai GH, Huang YF, Chen YF. A wearable ECG Apparatus for Ubiquitous Health care," in 2016 IEEE International Conference on Systems, Man, and Cybernetics, SMC 2016 Conference Proceedings; 2017. p. 4471-6.
- Miao F, Cheng Y, He Y, He Q, Li Y. A wearable context-aware ECG monitoring system integrated with built-in kinematic sensors of the smartphone. *Sensors (Basel)* 2015;15:11465-84.
- Rachim VP, Chung WY. Wearable noncontact armband for mobile ECG monitoring system. *IEEE Trans Biomed Circuits Syst* 2016;10:1112-8.
- Iamsamang J, Bijaphala N, Boonperm P, Lordthong R, Naiyanetr P. A modular vital sign monitoring based-on USB communication," in Proceedings of the 13th IASTED International Conference on Biomedical Engineering. *Bio Med* 2017;2017:241-6.
- Winokur ES, He DD, Sodini CG. A wearable vital signs monitor at the ear for continuous heart rate and pulse transit time measurements. *Conf Proc IEEE Eng Med Biol Soc* 2012;2012:2724-7.
- Shivakumar NS, Sasikala M. Design of vital sign monitor based on wireless sensor networks and telemedicine technology. *Proc IEEE Int Conf Green Comput Communicat Electric Eng* 2014;2014:1-5.
- Multiparameter Monitoring. Available from: <http://www.appannie.com/apps/ios/app/airstrip-patient-monitoring/>. [Last accessed on 2018 May 10].
- Tara K, Sarkar AK. Real-time monitoring of heart conditions via electrocardiogram processing at different lifestyle situations. *Int Conf Adv Elect Eng* 2017;2017:546-50.
- Anaesthesia UK, Electro-Cardiogram Signal. Available from: <http://www.frca.co.uk/article.aspx?articleid=339>. [Last accessed on 2018 May 12].
- Kashish K, Priya M, Yadav P. Design of low power pulse oximeter for early detection of hypoxemia. *Proc Int Conf Micro Electron Telecomm Eng* 2016;2016:600-5.
- Lopez S. *Pulse Oximeter Fundamentals and Design*, Freescale Semiconductor Application Note, Document Number: AN4327; 2012.
- Oak SS, Aroul P, How to Design Peripheral Oxygen Saturation (SpO2) and Optical Heart Rate Monitoring (OHRM) Systems Using the AFE4403, Application Report; SLAA655-March, 2015.
- Mayet J, Hughes A. Cardiac and vascular pathophysiology in hypertension. *Hear J* 2003;89:1104-9.
- Pollock JD, Murray I, Bordes S, Makaryus AN. *Physiology, cardiovascular hemodynamics*. In: StatPearls. Treasure Island (FL): StatPearls Publishing; 2020.
- Carr JL, Brow R. *Introduction to Biomedical Equipment Technology*. Prentice Hall: New Jersey; 2001.