

An Interfacing Digital Blood Pressure Meter with Arduino-GSM Module for Real-time Monitoring

Zulfikar Fajar M.R.

Telkom Applied Science School
Telkom University
Bandung, Indonesia
zfr.ramli@gmail.com

Sugondo Hadiyoso

Telkom Applied Science School
Telkom University
Bandung, Indonesia
sugondo@telkomuniversity.ac.id

Achmad Rizal

School of Electrical Engineering,
Telkom University,
Bandung, Indonesia
achmadrizal@telkomuniversity.ac.id

Abstract— Heart health is one of the parameters of one's health condition. Besides using the ECG machine, heart conditions can be determined through blood pressure measurement. Patient's hypertension requires the continuous blood pressure measurement. In some conditions, the health of patients cannot be directly checked at healthcare center. For this, the mobile blood pressure meter devices can send data in real time are deemed necessary. The paper discussed about the realization of an interface system that can automatically transmit the blood pressure measurements via Short Message Service (SMS) addressed to the doctor or the medical expert. The result then showed the validity of the test in the form of validation of sensor measurement data and output data SMS (systolic and diastolic). Based on the overall system test waiting time or delay between sending and receiving was at 46.27 seconds for once measurement.

Keywords—Heart, Blood Pressure, real time, SMS

I. INTRODUCTION

Heart is a vital organ of a human who requires much attention to keep it healthy. On the other hand, heart disease becomes one of the main causes of death in the world, and most people are still not aware of the importance of maintaining cardiac health. One of the causes of heart disease is hypertension – a condition where; blood pressure exceeds a normal pressure. Some patients with hypertension require an intensive care and monitoring to avoid a heart attack [1]. Hypertension is influenced by a number of psychological conditions and stress levels causing the blood pressure change suddenly [2]. The category of high blood pressure is >140 mmHg systolic pressure, or ≥ 90 mm Hg diastolic pressure [3].

For patients, periodic blood pressure check and consultation with medical experts is very important. With the reason of busyness, such check and consultation, however, are sometimes difficult to be done by the patient. In the purpose of consultation, a mobile blood pressure device is required to send the blood pressure value for the medical experts. Patients can conduct the blood pressure checks by themselves and

consult with medical experts anytime and anywhere. In other words, it takes a Tele-monitoring application to resolve the issue. One of communication media for telemonitoring application is SMS services via the GSM network that can be widely accessed.

Many studies have been conducted on blood pressure monitoring systems. Research on blood pressure data transmission for Tele-monitoring applications based on GSM module was reported by A. Srividhya [4]. The study reported a system of data transmission for blood pressure measurement based on GSM communication but did not discuss in detail about the results of measurement.

Another research by Dai Houde [5] developed the mobile blood pressure monitor with the wireless communication interface. Dai Houde applied a wireless communication module: NanoLOC AVR as a medium for transmitting data to the server. For further development, it needed integration with a PC or a mobile phone for computation.

Mandeep Singh [6] developed a smartphone-based wireless blood pressure monitoring system using Bluetooth. The results of blood pressure measurement were sent to the mobile phone via Bluetooth and displayed on the Android app.

From the description above it can be concluded that the needs of mobile devices for vital signs in monitoring human health is very important. One of the applications that is paid much attention is the monitoring of blood pressure. This paper aims to discuss the realization of digital BP meter system integrated with GSM network for monitoring a patient's blood pressure in real time. The patient can do the measurements by himself/herself and the device will automatically send the systole and diastole data to medical experts via SMS. The urgency of this research is the implementation of a system in health tele-monitoring for areas that are not reached by the internet service.

In our research, we developed blood pressure measurement system based on E-Health module. E-Health module was integrated with the Arduino to read the measurement data and then to be sent via short message service using the SIM 900 module. This environment is expected to help patient particularly outpatients to able to establish a communication with the medical expert periodically and for some emergency

cases, real-time applications are required. By so doing, the medical expert still could monitor patients' health remotely and provide early treatment if something happens to the patient.

The main contents of this paper are organized as follows; Section II describes the basic theory of digital blood pressure meter, E-health module and GSM module. Section III presents a description of system implementation. Section IV provides a brief description of the result discussed and this paper is ended with the conclusion given in Section V.

II. BASIC THEORY AND MATERIALS

A. Digital Blood Pressure Meter

The measurement of blood pressure is a measure of pressure in the arteries using a sphygmomanometer also called as tension meter. In this work, we used an automatic digital blood pressure meter product from Kodea (Model: KD 202F).

The device supports integration with other devices such as a PC, smartphone, or a microcontroller via USB for health management purposes. In this work, the blood pressure monitor was connected to the Arduino via E-Health Module.

B. E-Health Sensor Shield

E-Health sensor shield is a special module designed to meet the needs of medical device design based on Arduino. It is used for a communication interface between the sensor (BP meter) with Arduino. Figure 1 shows the E-Health sensor.



Fig 1. E-Health Shield [7]

C. GSM Modem

In this research, we used Wavecom Fastrack M1306B series modem as an SMS sender module. Wavecom modem enables Arduino board connected to a mobile network to send and receive SMS either in the form of text or in the PDU format. In principle, the process of sending and receiving SMS on Wavecom modem used AT command.

III. IMPLEMENTATION

This section describes the implementation of the system in detail including the scheme, system illustration, hardware, and software installation.

A. Scheme of Systems

Blood pressure meter for real-time monitoring via SMS service consists of Arduino board, E-Health shield, blood

pressure sensor, Wavecom Module and software platform. Fig 2 and Fig 3 display the scheme and illustration of the system.

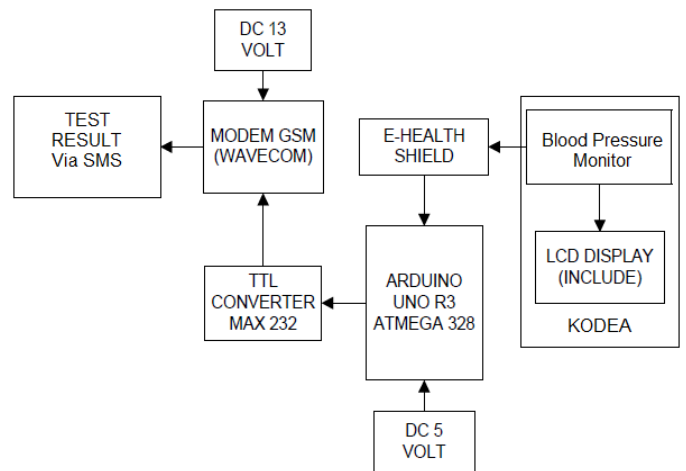

Fig 2. Block Diagram

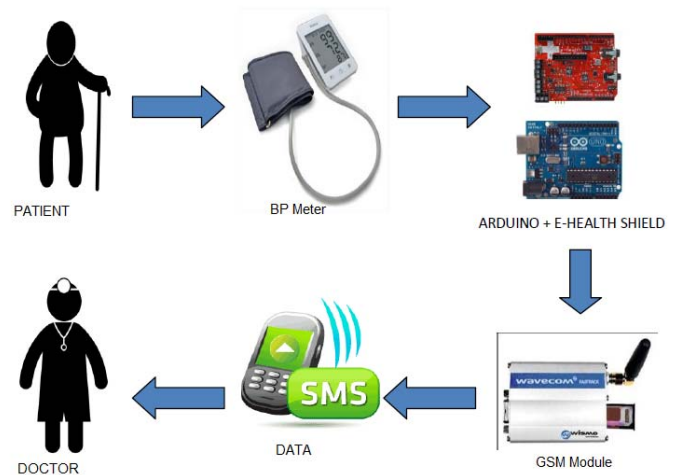

Fig 3. Illustration of Blood pressure measurement

In this system, the patient can do blood pressure measurement by means of the BP meter by himself/herself. After measurement, it will get the measurement results such as the systolic pressure, diastolic pressure, and heart rate. Automatically by the sensor, measurement data are transmitted in a serial mode to Arduino and will be processed by the microcontroller.

The data processed by a microcontroller automatically would be forwarded to the modem Wavecom Fastrack that has been integrated into Arduino board to send the measurement results to a medical specialist via SMS.

B. Hardware Installation

The overall design of the system was done by connecting the blood pressure sensor on E-Health Shield, which has been connected to the Arduino board. Arduino was also connected

to the GSM module with TTL to RS232 converter. Data rates for serial communication between the microcontroller, sensor and GSM module was 115200 bps. Data format setting was also conducted to create synchronization between sender and receiver. Hardware installation can be seen in Fig 4.

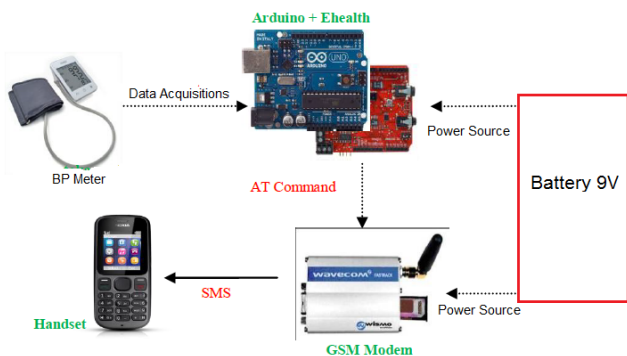

Fig 4. Hardware Implementation

Data communication between Wavecom modem and Arduino was run via null modem and TTL to RS232 converter. The wiring diagram of communication can be seen in Fig 5.

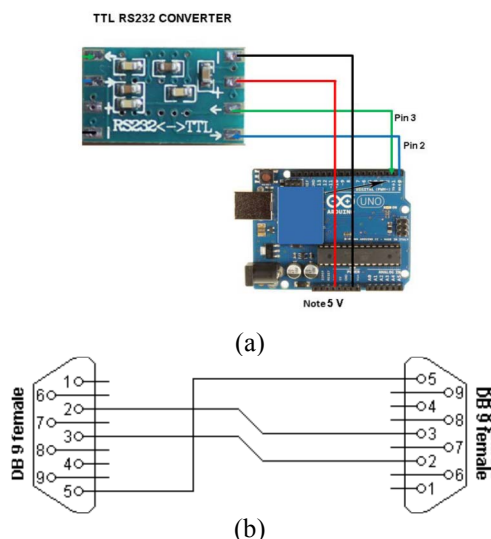

Fig 5. Wiring Diagram (a) TTL converter (b) null modem

C. Software Installation

Figure 6 describes the workflow of process system; the measurement was started when a patient used a cuff connected to BP meter. The measurement results obtained systolic pressure, diastolic pressure and heart rate simultaneously. Furthermore, the measurement data from the sensors would be sent via the serial data to Arduino Shield E-health. Finally, serial data would be processed by a microcontroller and sent via modem.

The measurement data was displayed via the SMS service in accordance with the authentication recipient.

The listing program of data transmission using the SMS based on AT-Command is presented as follows

```
void SendTextMessage() {
char mychar = 13;
char mychar2 = 26;
mySerial.print("AT+CMGF=1\r");
delay(100);
mySerial.println("AT + CMGS = \""+628231705xxx "\"");
delay(100);
mySerial.print(F("Systolic value : "));

mySerial.print(30+eHealth.bloodPressureDataVector[x]
.systolic);
mySerial.println(F(" mmHg"));
mySerial.print(F("Diastolic value : "));

mySerial.print(eHealth.bloodPressureDataVector[x].di
astolic);
mySerial.println(F(" mmHg"));
mySerial.print(F("Pulse value : "));

mySerial.print(eHealth.bloodPressureDataVector[x].pu
lse);
mySerial.println(F(" bpm"));
while (1>0);
}
```

IV. RESULT AND DISCUSSION

In this section we discuss the results of the testing system. The analysis is focused on the blood pressure data communication device as well as the performance of communication with Arduino GSM modem to send a short message service.

A. Communication BP Monitor with Arduino

This test aimed to determine whether the data presented by BP monitor successfully received Arduino before being forwarded to a GSM modem. Measurement data was sent serially by the Arduino to the PC for data validation. In each time sending the data consisted of a value of systole, diastole and pulse rate values. Arduino was programmed to send the latest measurement data only once in each test. Figure 6 show the testing scenario while Fig 7 display the BP measurement result on the serial monitor.

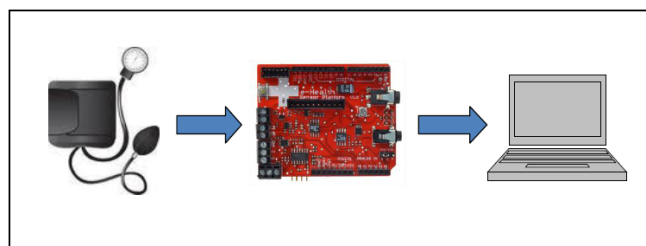

Fig 6. Sample test data transfer from BP monitor

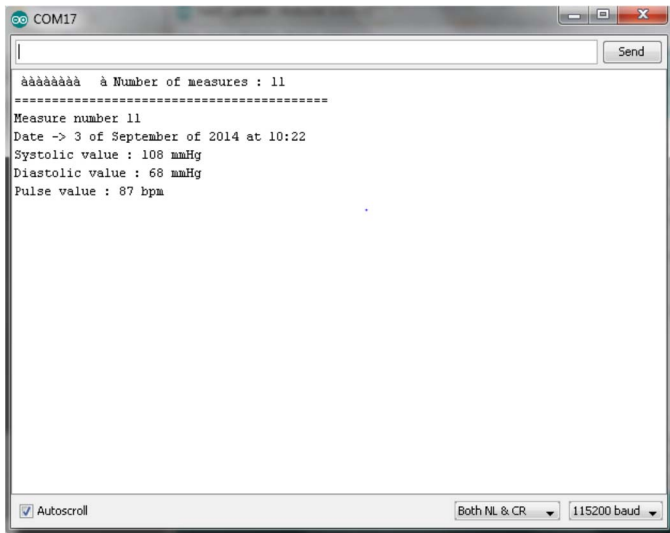

Fig 7. Sample data

B. Testing communication Arduino with GSM Modem

Interface testing between Arduino with GSM module aimed to determine the successful delivery of a short message and to observe the length of waiting time (delay) delivery. A total of 20 samples was sent over a GSM modem by the microcontroller and calculated the delay. The average delay message delivery was 16.75 seconds with the standard deviation of 1,251. The values of standard deviation were relatively low indicating that the difference of delay value was little. The delay test results can be seen in Fig 8.

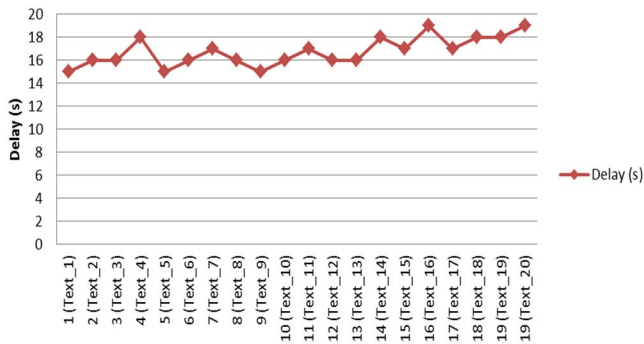

Fig 8. SMS Delay

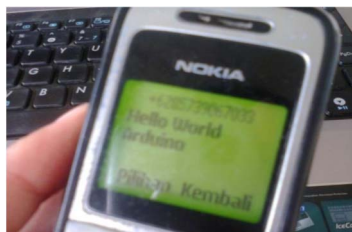

Fig 9. Sample SMS display on handset

C. Testing of Systems Integration

Testing the overall system was accomplished by integrating the entire circuit or the configuration of all modules required in the design of this system. Blood pressure sensor needed to be connected to the E-Health Shield, which has been connected to the Arduino board. At the same time, Arduino should also be connected to the GSM module. For the serial communication between the microcontroller, sensor and GSM module, they were set at the same rate. In addition, the type of data being transmitted in the program must also be set to synchronize transmitter and receiver.

TABLE I. TEST RESULT OF INTEGRATED SYSTEMS

Pat. ID	Systole	Diastole	HR	Delivery Status	Text Status	Delay (s)
1	128	73	84	sent	Valid	34
2	107	82	83	sent	Valid	35
3	117	78	83	sent	Valid	33
4	111	78	83	sent	Valid	40
5	104	75	84	sent	Valid	46
6	108	78	78	sent	Valid	33
7	125	79	80	sent	Valid	35
8	117	79	86	sent	Valid	35
9	120	85	86	sent	Valid	35
10	131	115	99	sent	Valid	38
11	126	87	89	sent	Valid	42
12	111	94	87	sent	Valid	39
13	148	138	101	sent	Valid	40
14	138	84	85	sent	Valid	122
15	125	87	81	sent	Valid	44
16	116	81	81	sent	Valid	38
17	149	114	114	sent	Valid	41
18	116	87	86	sent	Valid	44
19	134	113	91	sent	Valid	54
20	120	85	86	sent	Valid	74
21	127	89	89	sent	Valid	65
22	125	89	89	sent	Valid	94
23	126	89	88	not sent	N/A	N/A
24	133	97	85	not sent	N/A	N/A

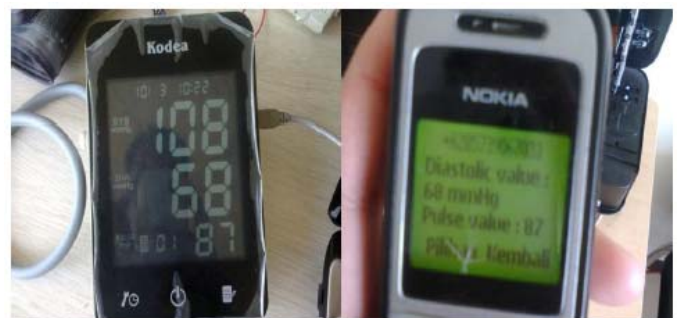

Fig 10. validation of the results between the sensor data and SMS data

From the test results as shown in Table 1, it can be stated that the measurement data was successfully sent. When referring to the GSM communication the test results only

showing text messages can show a waiting time difference or delay between sending and receiving SMS.

Of 24 times of testing, the range of delay between transmitting and receiving SMS was from 33 to 122 seconds, and the average was 48.27 seconds. This result was related to the relatively slower data processing in the microcontroller as the microcontroller must acquire data from sensors in advance before being processed into a short message format and sent to the medical side.

V. CONCLUSIONS

In this paper, we presented an implementation of blood measurement system with GSM module for telemonitoring. The evaluation result showed that the system could work appropriately. The data resulted from measurement were sent and received with a valid value via SMS. The average delay in the transmission was 48.27 seconds. The connection between the blood pressure sensor and Arduino could not run simultaneously when the data acquisition process by the microcontroller were running. Thus, when a data acquisition process would be performed, the cable between the sensor and the e-health shield must be manually connected.

REFERENCES

- [1] [National Heart Foundation of Australia, Guideline for the diagnosis and management of hypertension in adults. National Heart Foundation of Australia, 2016.
- [2] A. Steptoe, M. Hamer, and Y. Chida, "The effects of acute psychological stress on circulating inflammatory factors in humans: A review and meta-analysis," *Brain. Behav. Immun.*, vol. 21, no. 7, pp. 901–912, 2007.
- [3] D. Conen, P. M. Ridker, S. Mora, J. E. Buring, and R. J. Glynn, "Blood pressure and risk of developing type 2 diabetes mellitus: The Women's Health Study," *Eur. Heart J.*, vol. 28, no. 23, pp. 2937–2943, 2007.
- [4] A. S. Rividhya, G. E. R. Avikanth, and M. S. Rinivasulu, "New Design for Patient Monitoring Based on GSM Module," *Int. J. Scientific Eng. Technol. Res.*, vol. 4, no. 28, pp. 5443–5446, 2015.
- [5] H. D. H. Dai, L. T. D'Angelo, and T. Lueth, "Continuous blood pressure monitor with wireless interface," *Robot. Biomimetics (ROBIO)*, 2010 IEEE Int. Conf., 2010.
- [6] M. Singh and N. Jain, "Performance and Evaluation of Smartphone Based Wireless Blood Pressure Monitoring System Using Bluetooth," *IEEE Sens. J.*, vol. 16, no. 23, pp. 8322–8328, 2016.
- [7] Cooking-hacks.com, "E-Health Sensor." [Online]. Available: https://www.cooking-hacks.com/documentation/tutorials/ehealth-biometric-sensor-platform-arduino-raspberry-pi-medical#get_kits